

MHE
ITEM

STOCKY™ MOVABLE DOCK RAMP

DCQY SERIES

Versatile Dock Ramp

Movable dock ramp is a specially designed equipment that aids in quick loading and unloading of goods. Material handling equipment such as forklifts and other trucks can easily be maneuvered on the dock ramp to unload and load good efficiently.



Adjust Height

The height of platform from ground can be adjusted according to the height of the truck.



Attached Brake

The attached brake can prevent dock ramp from moving and shaking.

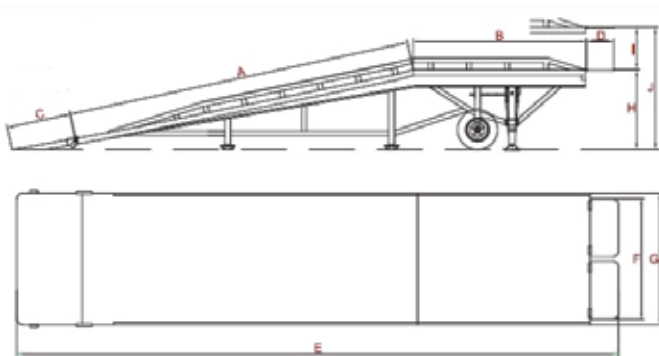
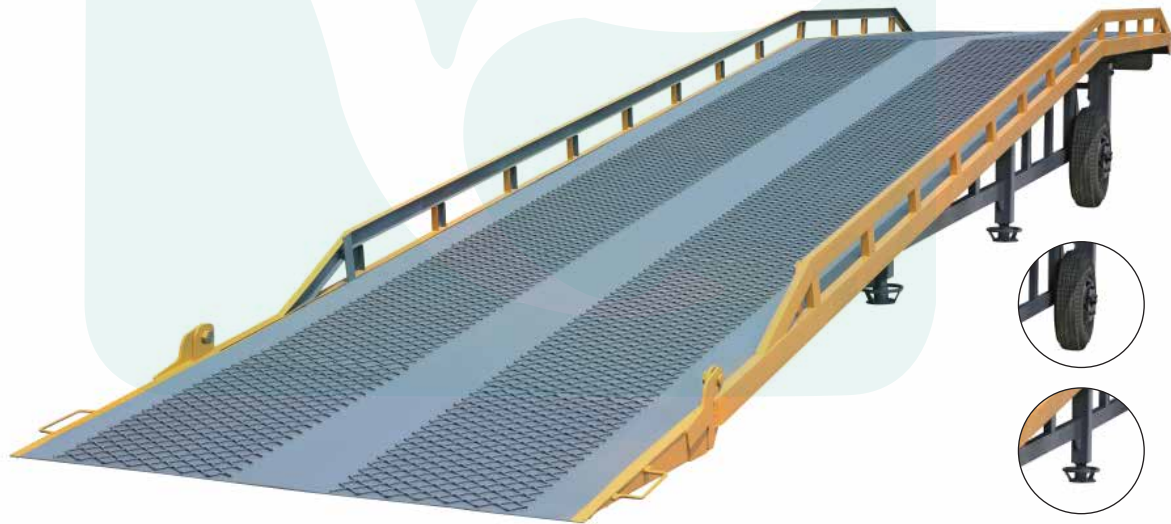

CODE	DCQTY6-0.4	DCQTY8-0.4	DCQTY10-0.4
LOADING CAPACITY	6000KG	8000KG	10 000KG
PLATFORM SIZE			
A	6000 mm	6000 mm	7000 mm
B	3000 mm	3000 mm	3000 mm
C	1000 mm	1000 mm	1000 mm
D	300 mm	300 mm	300 mm
E	10300 mm	10300 mm	11300 mm
F	1800 mm	1800 mm	1800 mm
G	2100 mm	2100 mm	2100 mm
H	1200 mm	1200 mm	1200 mm
J	1600 mm	1600 mm	1600 mm
I	400 mm	400 mm	400 mm

WWW.PRESTARMARKETING.COM.MY

VERSION DATE: 8/7/25

PRESTAR MARKETING SDN BHD has solid partnerships with a variety of industries, including construction, industrial supplies, DIY concept stores, logistics, and warehousing. We are one of the largest distributors for: Storage, Racking and Logistics products | Warehouse equipments, parts and service and repairs | Material handling equipments | Hardware

PRESTAR MARKETING SDN BHD
Lot 3811, Jalan 4D, Kampung Baru Subang, 40150 Shah Alam, Selangor, Malaysia.
Hotline: +6012-328 3811 | Email: inquiry@prestar.marketing