

MHE
ITEM

STOCKY™
PALLET TRUCK SERIES

FORK TYPE : STANDARD



Ergonomic Handle

Has neutral setting for easy usage. Handle would return to its original position when being released.



AC Pump

The cast press, one-piece pump controls jostling and a chrome-plated cylinder for longer pump life.



Durable Wheels

Rolling-resistance PU for smooth execution and taking care of. Roller framework gives trouble-free bed section and exit.



Single PU Load Wheel

Single wheels are ideal because they allow for easy turning.



Nylon Wheels

Its impact strength is substantially higher than that of typical plastics, and it has

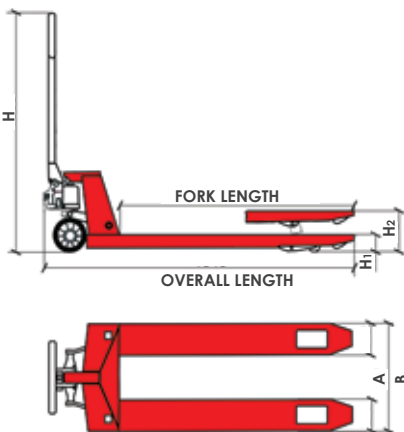
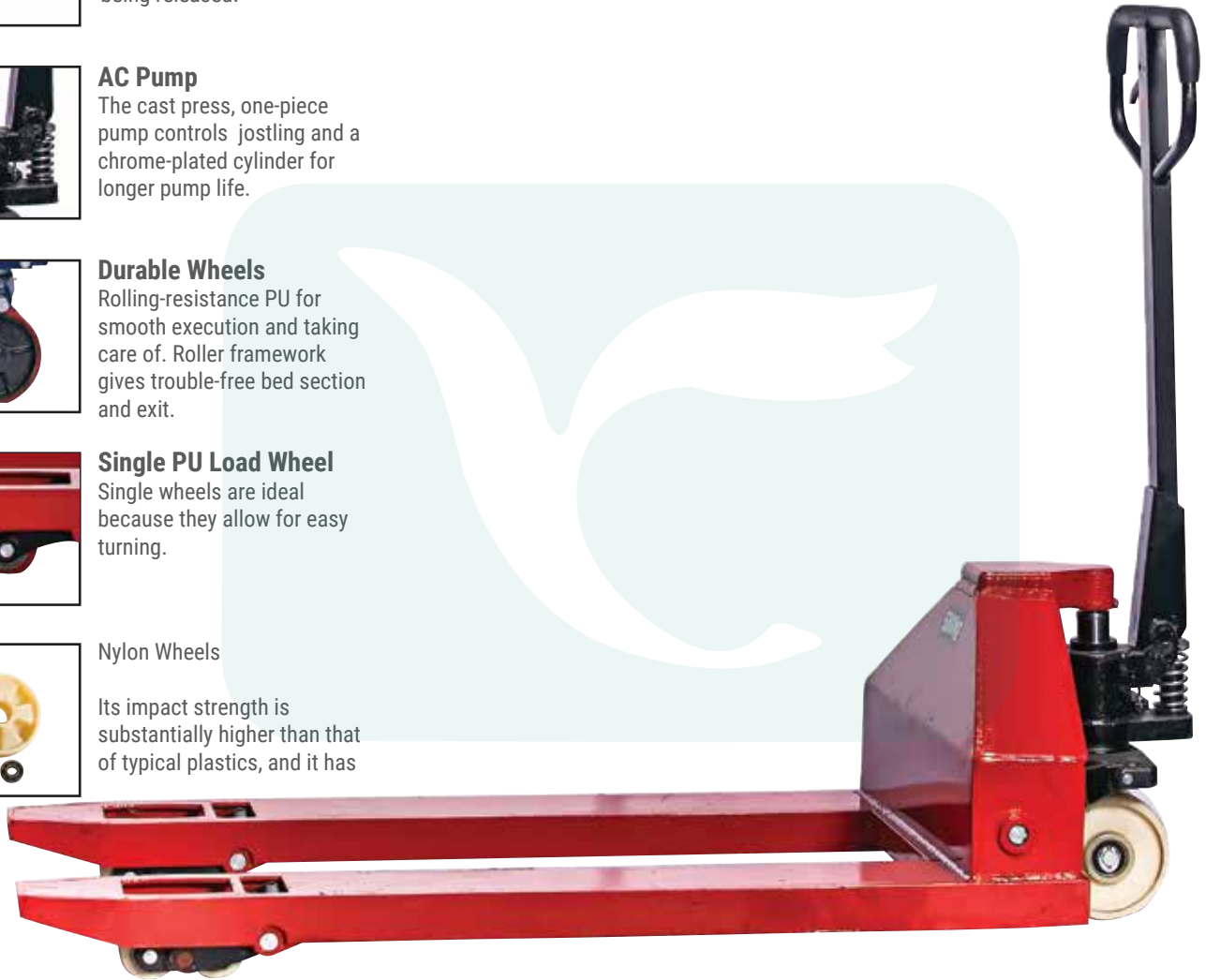

CODE	HP50SE
LOADING CAPACITY (KG)	5000
OVERALL DIMENSION (W x L x H)	85 x 685 x 1220 mm
FORK HEIGHT LOWERED, RAISED	85, 195 mm
FORK WIDTH	160 mm
INTERNAL FORK WIDTH	365 mm
OVERALL FORK WIDTH	685 mm
FORK LENGTH	1220 mm
LOAD WHEEL	80 x 70 mm NYLON WHEEL
STEERING WHEEL	180 x 50 mm NYLON
FORK TYPE	STANDARD

WWW.PRESTARMARKETING.COM.MY

VERSION DATE: 8/7/25

PRESTAR MARKETING SDN BHD has solid partnerships with a variety of industries, including construction, industrial supplies, DIY concept stores, logistics, and warehousing. We are one of the largest distributors for: Storage, Racking and Logistics products | Warehouse equipments, parts and service and repairs | Material handling equipments | Hardware

PRESTAR MARKETING SDN BHD
Lot 3811, Jalan 4D, Kampung Baru Subang, 40150 Shah Alam, Selangor, Malaysia.
Hotline: +6012-328 3811 | Email: inquiry@prestar.marketing