

MHE
ITEM

STOCKY™
MOVABLE DOCK RAMP

DCQH SERIES

Versatile Dock Ramp

Movable hydraulic dock ramp is a specially designed equipment that aids in quick loading and unloading of goods. Material handling equipment such as forklifts and other trucks can easily be maneuvered on the dock ramp to unload and load good efficiently.



Adjust Height

The height of platform from ground can be adjusted according to the height of the truck.



Attached Brake

The attached brake can prevent dock ramp from moving and shaking.

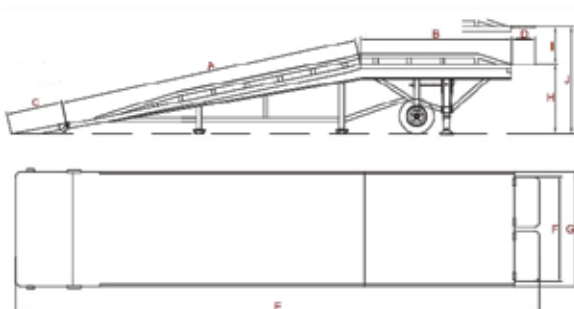

CODE	DCQH6-0.6	DCQH8-0.6	DCQH10-0.6
LOADING CAPACITY	6000KG	6000KG	7000KG
PLATFORM SIZE			
A	6000 mm	6000 mm	7000 mm
B	3000 mm	3000 mm	3000 mm
C	1000 mm	1000 mm	1000 mm
D	300 mm	300 mm	300 mm
E	10300 mm	10300 mm	11300 mm
F	1800 mm	1800 mm	1800 mm
G	2100 mm	2100 mm	2100 mm
H	1100 mm	1100 mm	1100 mm
J	1700 mm	1700 mm	1700 mm
I	600 mm	600 mm	600 mm