

# **STOCKY**™ Electric Pallet Truck Series

 Durable and robust design

**Electric Pallet Truck**  
FEP 20NR-20SE / 2000KG



# FEATURES

## Electric Pallet Truck - Fork Over



Integral Forks



Canbus Multifunction Intelligent Handle With code Lock

Protective Cover



48V LFP battery, easy replacement, low energy consumption, long working time, safer and stable cell with long service life.

Optional: Tandem & Single PU Load roller

## OVERVIEW

The Stocky FEP20NR and FEP20SE electric pallet trucks have a capacity up to 2000kg, respectively, and are a great alternative to hand pallet trucks. It will improve material handling efficiency while lowering overall costs, particularly labour costs.

### The Range

The Stocky Electric Pallet Truck range is available in two different capacities:

- 2,000KG – FEP20NR (Narrow Forks)
- 2,000KG – FEP20SE (Standard Forks)

### Design

In case of a collision, components and the battery are protected with special designed cover. The welded fork construction and reinforced compact chassis makes the truck resistant to torsion with heavy loads.

- Fast charging Lithium battery
- Easy battery replacement
- High maneuverability
- Ideal for occasional operations



- 48V/850w DC Brushless Motor
- Maintenance Free
- Big Transmission Ratio Gearbox

- 48V/15ah Lithium Battery
- Maintenance Free
- Easy Replacement
- One Year Warranty

- Recharge Alert

- Error Code Display (Canbus Handle)
- 5s Replace Battery
- 60s Replace Drive Wheel

- Laden / Unladen
- 4.5KM/H

## Operator Productivity

The standard anti-roll back system, stabilising wheels to maximize stability when turning and single load wheels and exit/entry roller optimise pallet handling for operator peace of mind.

## Industry Sectors:

- Food Distribution and Processing
- Beverage
- Cold & Frozen Foods
- Agriculture
- Warehouse & 3PL
- Wholesale Distribution
- Chemicals & Plastics
- Auto & Transport MFG
- Building Materials
- General MFG
- Retail & E-Commerce (DC/fulfillment)
- Retail Store Operations
- Health & Pharma
- Auto Parts Distribution
- Furniture & Furnishing

# ○ SPECIFICATIONS

1.1	Brand	Measurement	STOCKY	STOCKY
1.2	Model designation		FEP20NR	FEP20SE
1.3	Drive		Full Electric	
1.4	Operation		Pedestrian	
1.5	Load capacity	kg	2000	
1.6	Load centre	c (mm)	600	
1.7	Load distance, centre of drive axle to fork	x (mm)	840	910
1.8	Wheelbase	y (mm)	1220	
1.9	Net Weight	kg	140	
2.1	Tire		Polyurethane	
2.2	Tire Size, Drive	Xw (mm)	Ø 190 * 70	
2.3	Tire Size, Rear	Xw (mm)	Ø 80 * 93 (Single Load Roller)	
			Ø 80 * 70 (Tandem Load Roller)	
2.4	Wheels, number (Drive / Rear)		1 / 2(Single), 4(Tandem)	
2.5	Tread, Rear	b11 (mm)	105 / 115	
2.6	Lifting Height	h3 (mm)	75 - 190	85 - 190
2.7	Height of Tiller in Drive Position Min/Max	h14 (mm)	800 - 1240	
2.8	Lowered Height	h13 (mm)	75	85
2.9	Overall Length	L (mm)	1540	1610
3.1	Length of Face of Forks	L1 (mm)	390	
3.2	Overall Width	b1 (mm)	560	680
3.3	Fork Dimension (s/e/l)	mm	50 * 160 * 1150	50 * 160 * 1120
3.4	Width Across Forks	b5 (mm)	560	680
3.5	Ground Clearance, centre of wheelbase	m2 (mm)	30	
3.6	Aisle width with pallets 800 x 11200 lengthways	Ast (mm)	1740	
3.7	Turning radius	Wa (mm)	1350	
3.8	Travel speed, Laden / Unladen	KM/H	4.5	
3.9	Tortoise Speed	KM/H	2.25	
4.1	Lift Speed, Laden / Unladen	m <sup>s</sup>	17 / 22	
4.2	Lowering speed, Laden / Unladen	m <sup>s</sup>	26 / 30	
4.3	Max Gradeability, Laden / Unladen	%	8 / 10	
4.4	Service Brake		Electromagnetic brake	
4.5	Drive Motor Rating	kw	0.85	
4.6	Lifting Motor Rating	kW	0.6	
4.7	Battery Voltage	V/AH	48V 15AH	
4.8	Battery weight	kg	6.3	
4.9	Charging time	Hours	1-2	
5.1	Working time after full charge	H	3-4 hours	

Details



**○ DIMENSIONS**

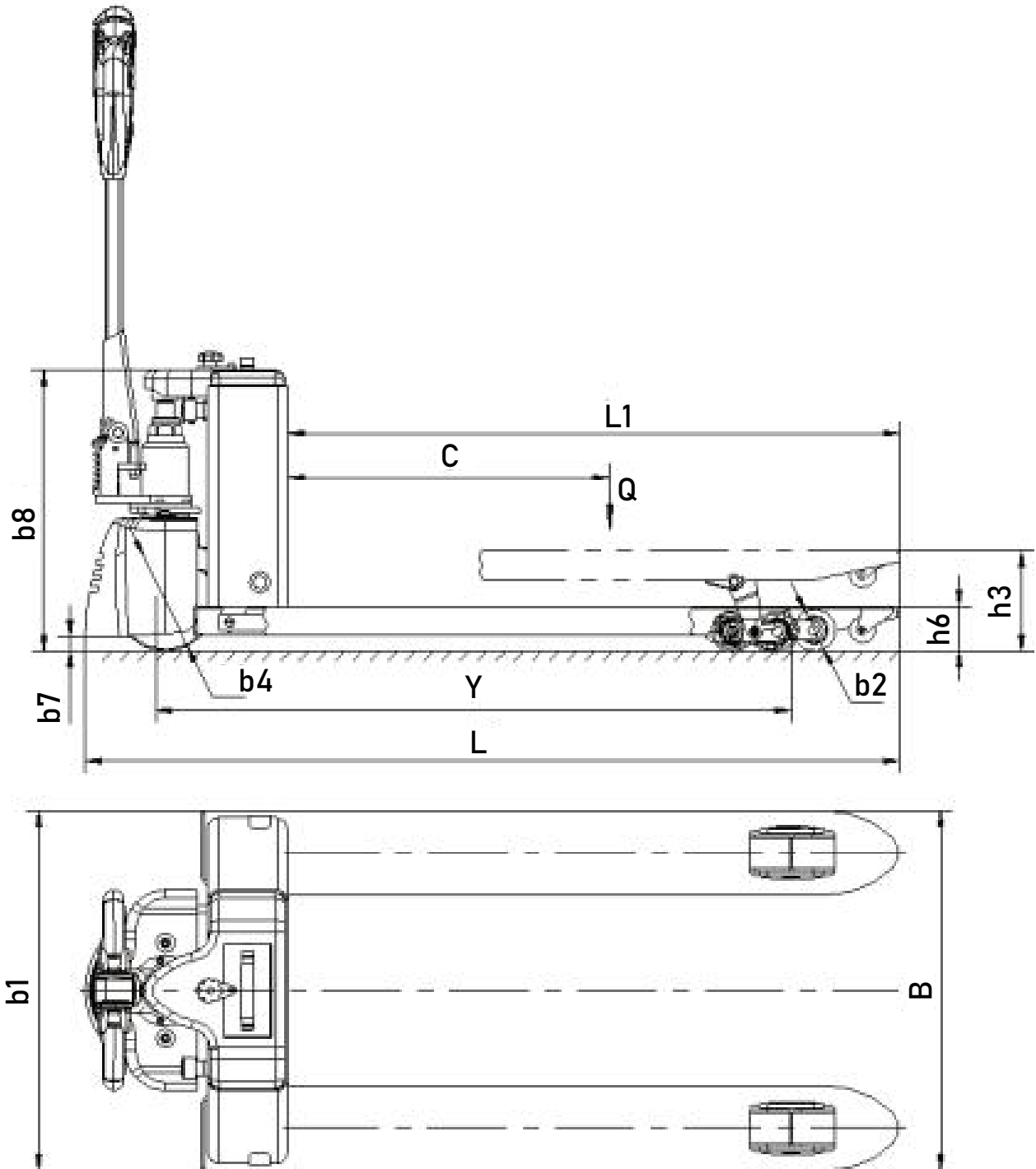



Contact your nearest  
branch by visiting  
[www.prestarmarketing.com.my](http://www.prestarmarketing.com.my)



**Prestar Marketing Sdn Bhd**

**Operating Hours**

Monday - Friday 9:00 AM - 6:00 PM

Saturday - Sunday Closed

\*Closed on Public Holiday

📍 Lot 3811, Jalan 4D, Kampung Baru Subang, 40150 Shah Alam, Selangor, Malaysia.

☎ +603-7455 7070

📠 +603-7455 7066 / 7455 7099

✉ [inquiry@prestar.marketing](mailto:inquiry@prestar.marketing)

©Prestar Marketing Sdn Bhd 2023. All rights reserved. Specifications and details in this brochure are subject to change without prior notification.

**Penang**

📍 65-A, Jalan Perak, 10150 George Town, Pulau Pinang, Malaysia.

☎ +604-228 7100

📠 +604-229 5580

**Johor**

📍 4, Jalan Penaga 5, Kawasan Perindustrian Kota Puteri, 81750 Masai, Johor, Malaysia.

☎ +607-3880 323

📠 +607-3884 323

[www.prestarmarketing.com.my](http://www.prestarmarketing.com.my)



Pallet Truck may be shown with optional equipment.