

# Yale UX Series

Internal Combustion Counterbalanced Forklift

GDP25-30UX / 2500 - 3000kg



# FEATURES

## High Strength OHG

The overhead guard features profiled steel with high strength glass to enhance reliability and operator protection.

## Suspension Seat

A full suspension seat that offers excellence in comfort, with an operator presence system fitted as standard.

## Low Step Driver Height

Convenient step placing to suit a variety of heights to ensure easy access to the truck at all times.



## OVERVIEW

The Yale® UX Series provides the ideal solution to meet your less frequent usage needs, without compromising on performance.

### The Range

The range consists of 2,500 - 3,00kg. IC counterbalance, pneumatic tyre forklift trucks, available in four different capacities:

2,500KG – GDP25UX  
3,000KG – GDP30UX

### Design

The UX series has ergonomically designed operator compartment, with a familiar automotive layout, means that drivers will be able to work comfortably. A range of standard features and options help to ensure that the truck is configured to the needs of the application.

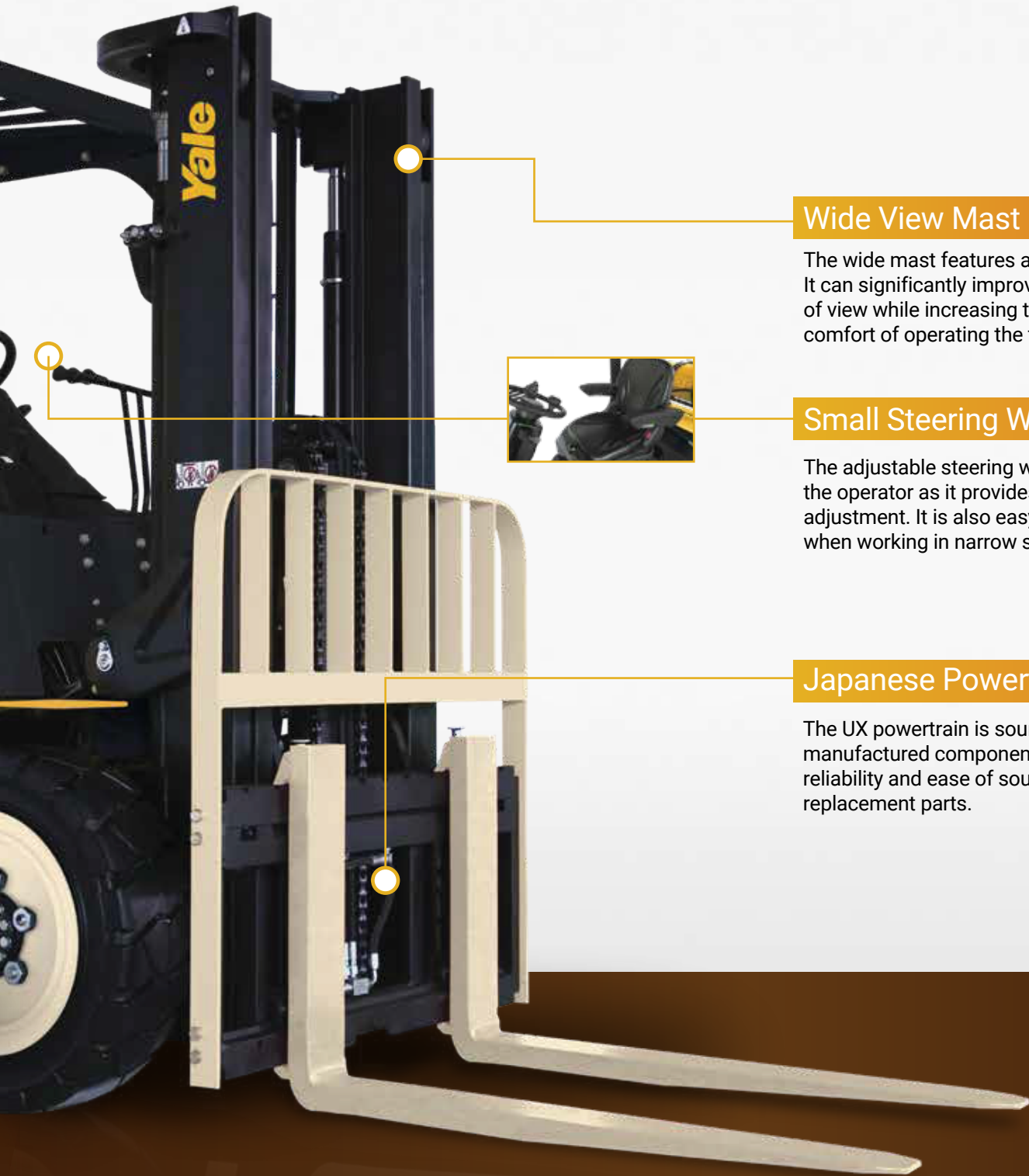

### Wide View Mast

The wide mast features an outside width of 720mm. It can significantly improve the driver's front field of view while increasing the safety and comfort of operating the truck.



### Small Steering Wheel

The adjustable steering wheel is convenient for the operator as it provides 8 degrees of adjustment. It is also easy to navigate when working in narrow spaces.

### Japanese Powertrain

The UX powertrain is sourced from Japanese manufactured components which ensures reliability and ease of sourcing replacement parts.

## Fulfills Various Requirements

Each model is available with diesel, LPG or dual-fuel power, a single-speed powershift transmission and a range of front end equipment options to suit varying application requirements.

## Low Cost of Ownership

The use of high quality, robust components, efficient filtration and excellent cooling helps contribute to reliable operations and lower wear and tear. This, together with the fast availability of cost-effective replacement parts helps to reduce service and maintenance requirements and costs.

## ENGINEERED FOR DRIVERS



### ○ Yale Display with 3.5" LCD

- The Yale UX Series Forklift adopts a 3.5" LCD display, providing convenient viewing of the display data when driving and operating



### ○ Hand Parking Brake

- Low effort to operate park brake lever
- Hand parking brake lever with button reduces operator fatigue



### ○ Large Foot Room

- Spacious foot room design provides comfort, convenience and safety
- Control pedals provide extra foot space which reduces operator fatigue and increases operator comfort

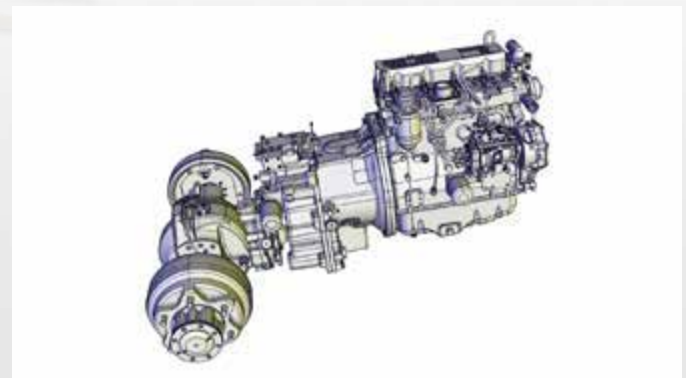

### ○ Dual Suspension System

- The specialised dual-suspension system
- decreases vibration and noise
- Full floating safeguard/cabin system
- Engine vibration damper
- Suspended transmission replaces traditional rigid connections

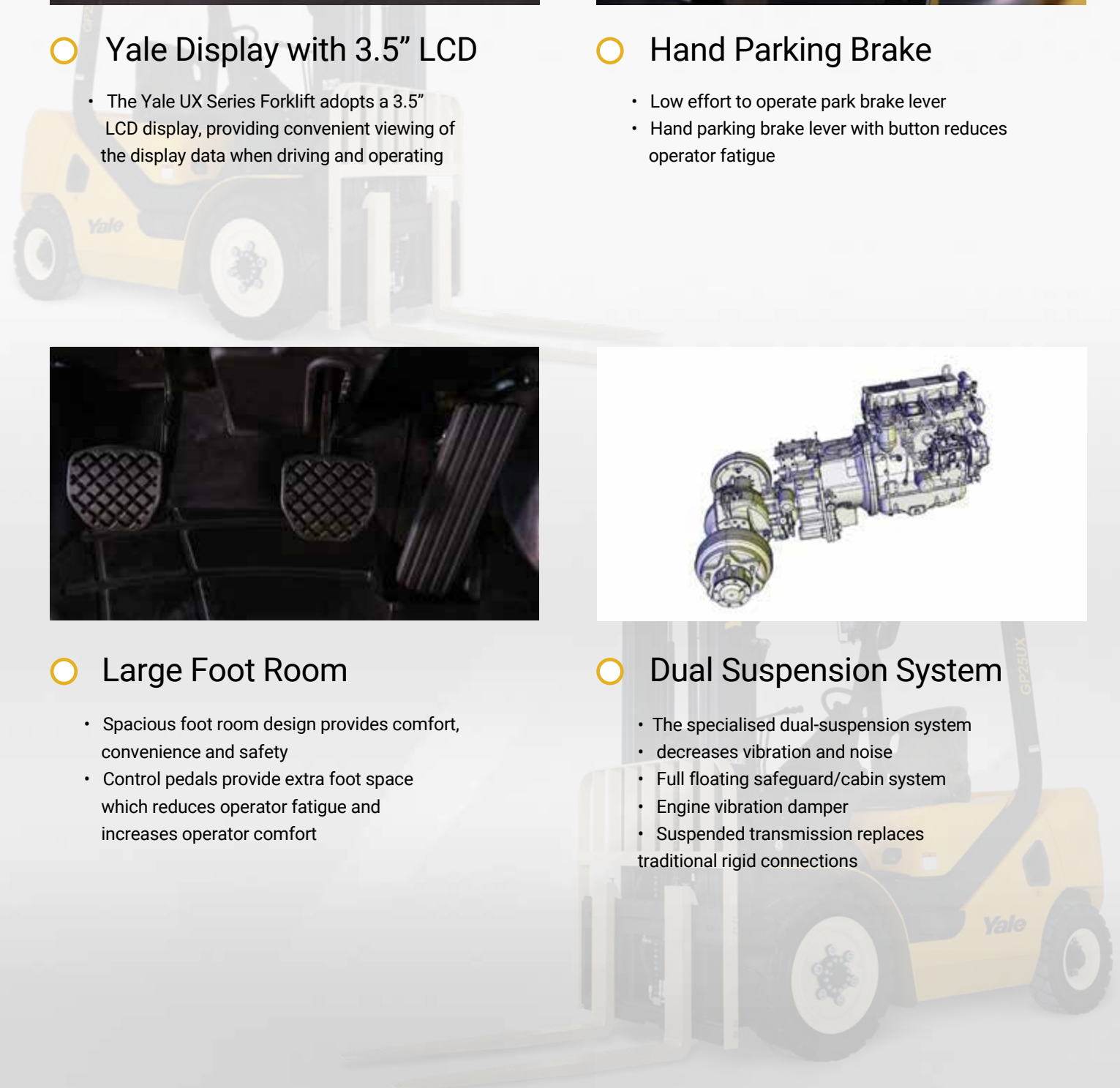

## ENGINEERED FOR DRIVERS



○ **Small Diameter Steering Wheel with Adjustable Steer Column**

- The 300mm diameter steering wheel is easy to manipulate, responsive, and ensures optimum mobility when working in a narrow space
- The ideally positioned steering wheel allows 8 degrees of adjustment, to suit a variety of different operators



○ **High Strength Overhead Guard**

- Profiled steel overhead guard
- High strength roof with high strength glass enhances reliability and operator protection
- Mast composite roller structure



○ **Wide View Mast**

- The wide view mast with an outside width of 720mm, significantly improves the driver's front field of view, reduces blind spots, and increases the safety and comfort of the operation



○ **Large Access Area for Service and Repairs**

- Large access space to engine compartment makes service and repairs more convenient

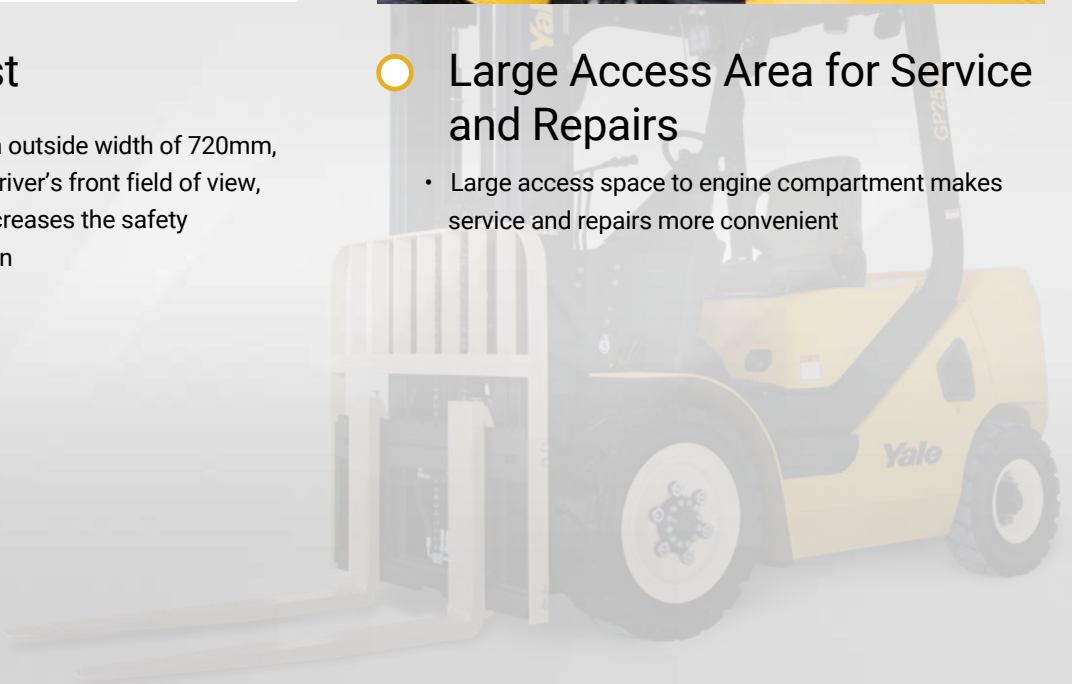

## ○ FEATURES

# ENGINEERED FOR DRIVERS



### ○ Suspension Seat

- Full suspension seat offers excellent comfort
- Operator presence system as standard



### ○ Triplex Plate Overhead Guard

- The overhead guard is developed using three pieces; left side, right side and top canopy making replacement more convenient



### ○ Exchangeable Components

- Engine cover, instrument panel, display and most other components are exchangeable with other capacities in the same range
- Front fenders adaptable to single or dual wheel configuration
- Improved Lifting Speed

### ○ Options

Yale UX Series trucks feature a comprehensive range of standard equipment, with a number of options available to suit the specific needs of your application, including:

- LPG, dual-fuel or diesel
- Pneumatic-shaped solid, or dual tyres
- Various fork lengths
- Integral sideshift
- Swing-out drop down LPG bracket
- Rear, LED work light
- Strobe light
- Backup alarm
- High air intake with pre-cleaner
- Tilt cylinder boots
- Various mast heights
- 3 way catalytic purifier on LPG engines
- Glass roof
- Front window with wiper



## MAST SPECIFICATIONS

### GDP25UX Rated Capacity KG@ 500MM Load Centre

	Maximum fork height $h_3 + s$ (mm)	Mast tilt		Lowered height $h_1$ (mm)	Extended height $h_4$ (mm) (1)	Extended height $h_4$ (mm) (2)	Free lift height $h_2 + s$ (m) (1)	Without Sideshift	
		FWD tilt (°)	Back tilt (°)					GP25UX	
								Single Tyre	Dual Tyre
2-STAGE LIMITED FREE LIFT	3000	6	12	2010	3575	3990	160	2500	2500
	3300	6	12	2160	3875	4290	160	2500	2500
	3700	6	6	2360	4275	4690	160	2500	2500
3-STAGE FULL FREE LIFT	4500	6	6	2060	5017	5490	1440	2000	2300
	4800	6	6	2160	5317	5790	1540	1700	2000
	5500	3	6	2425	6017	6490	1800	1200	1600

Note: For integral sideshifts deduct 50kg from stated capacity

### GDP30UX Rated Capacity KG@ 500MM Load Centre

	Maximum fork height $h_3 + s$ (mm)	Mast tilt		Lowered height $h_1$ (mm)	Extended height $h_4$ (mm) (1)	Extended height $h_4$ (mm) (2)	Free lift height $h_2 + s$ (m) (1)	Without Sideshift	
		FWD tilt (°)	Back tilt (°)					GP30UX	
								Single Tyre	Dual Tyre
2-STAGE LIMITED FREE LIFT	3000	6	12	2075	3640	4100	165	3000	3000
	3300	6	12	2225	3940	4400	165	3000	3000
	3700	6	6	2425	4340	4800	165	3000	3000
3-STAGE FULL FREE LIFT	4500	6	6	2125	5100	5600	1525	2500	2700
	4800	6	6	2225	5400	5900	1625	2250	2450
	5500	3	6	2490	6100	6600	1880	1650	2100

Note: For integral sideshifts deduct 50kg from stated capacity

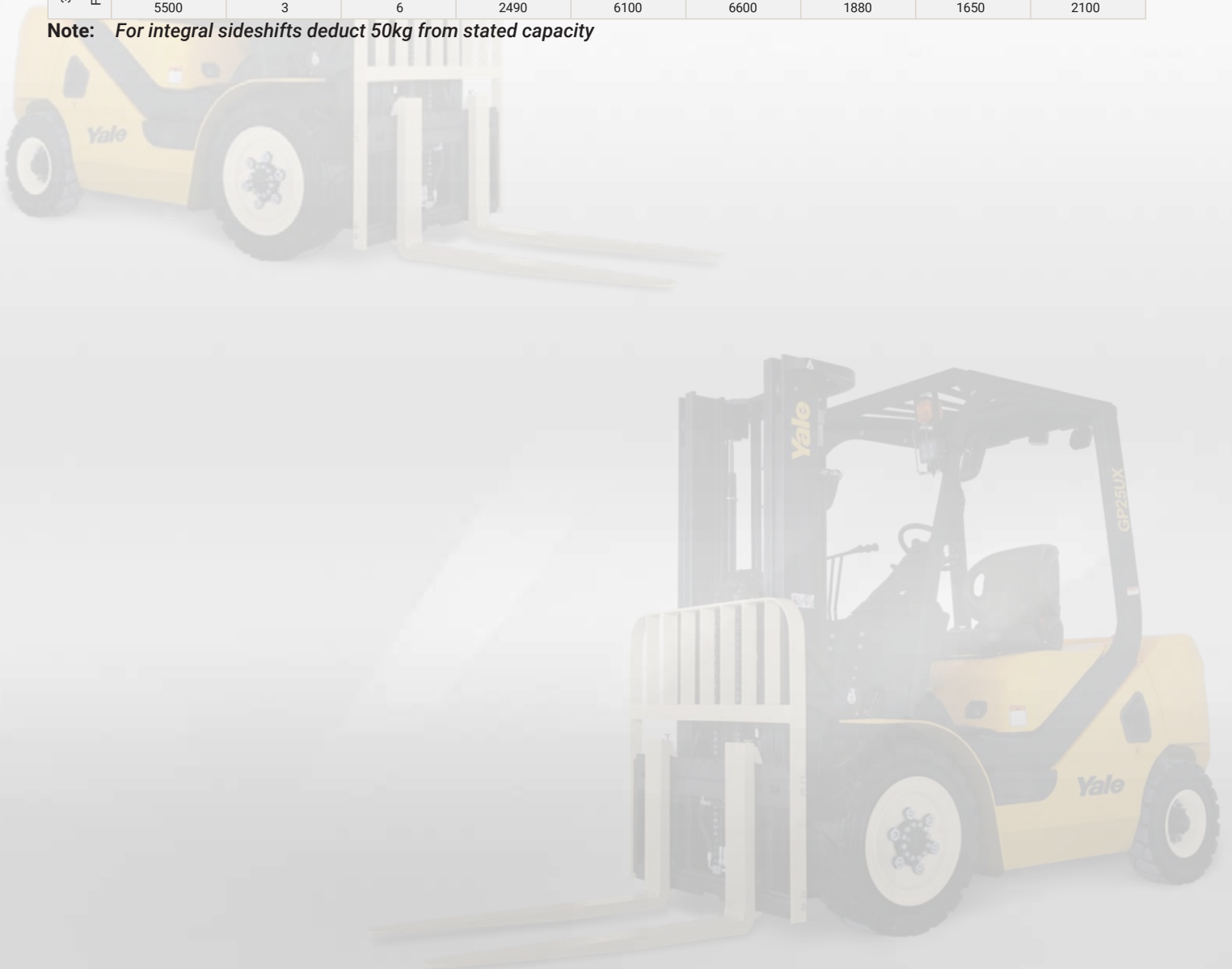

# SPECIFICATIONS

	1.1	Manufacturer	Measurement	YALE	YALE
Distinguishing mark	1.2	Model designation		GDP25UX	GDP30UX
	1.3	Engine / transmission		Yanmar 2.6L	Yanmar 3.0L
	1.4	Drive: electric (battery or mains), diesel, petrol, fuel gas		Diesel	
	1.5	Operator type: hand, pedestrian, standing, seated, order-picker		Seated	
	1.6	Rated capacity/rated load	Q (kg)	2500	3000
	1.7	Load centre distance	c (mm)	500	
	1.8	Load distance, centre of drive axle to fork	x (mm)	475	490
	1.9	Wheelbase	y (mm)	1600	1700
	Weight	2.1	Service weight	kg	3650
2.2		Axle loading, laden front / rear	kg	5320 / 650	6490 / 770
2.3		Axle loading, unladen front / rear	kg	1500 / 2150	1710 / 2590
Tyres, chassis	3.1	Tyre type		Pneumatic	
	3.2	Wheels, number front/rear (X = driven wheels)		2X/2	
	3.3	Tread, front	b10 (mm)	970	1000
	3.4	Track width, rear	b11 (mm)	980	970
Dimensions	4.1	Tilt of mast / fork carriage forward / backward	(°)	6 / 12	
	4.2	Height of mast, lowered	h10 (mm)	2010	2075
	4.3	Free lift	h2 (mm)	160	165
	4.4	Lift height	h3 (mm)	3000	
	4.5	Height of mast, extended	h4 (mm)	3575	3640
	4.6	Height to top of overhead guard	h6 (mm)	2180	2205
	4.7	Seat height	h7 (mm)	1167	1192
	4.8	Towing coupling height	h10 (mm)	250	480
	4.9	Overall length (with forks)	l1 (mm)	3690	3804
	4.10	Length to face of forks	l2 (mm)	2620	2734
	4.11	Overall width	b1 (mm)	1150 / 1590	1210 / 1650
	4.12	Fork dimensions	s/e/l (mm)	40 x 122 x 1070	45 x 122 x 1070
	4.13	Fork carriage DIN 15173. Class, A/B		A	A
	4.14	Fork carriage width	b3 (mm)	1040	1100
	4.15				
	4.16	Ground clearance, laden, below mast	m1 (mm)	125	130
	4.17	Ground clearance at centre of wheelbase	m2 (mm)	150	145
	4.18	Aisle width with pallets 1000mm long x 1200mm wide	Ast (mm)	4026	4126
	4.19	Aisle width with pallets 800mm wide x 1200mm long	Ast (mm)	3826	3926
	4.20	turning radius	Wa (mm)	2350	2430
	4.21	Inner turning radius	b13 (mm)	136	203
Performance data	5.1	Travel speed laden/unladen	km/h	20 / 20	
	5.2	Lifting speed laden/unladen	m/s	0.54 / 0.57	0.46 / 0.49
	5.3	Lowering speed laden/unladen	m/s	0.43 / 0.40	0.38 / 0.36
	5.4	Gradeability, laden / unladen @ 4.8 km/h	%	16.3/22.3	21.2/22.3
	5.5	Service brake		Hydraulic	
Combustion Engine	6.1	Engine manufacturer/type		Yanmar 2.6L	Yanmar 3.0L
	6.2	Engine power according to ISO 1585	kW	33	35.5
	6.3	Rated speed	min-1	2450	2400
	6.4	Number of cylinders/displacements	(-)/cm3	4 / 2659	4 / 3054
Add. data	7.1	Type of drive unit		Automatic	
	7.2	Operating pressure for attachments	bar	0-175	
	7.3	Oil volume for attachments	l/min	64	
	7.4	Average noise level at operator's ear (no cab)	dB(A)	84	
	7.5	Guaranteed sound power 2001/14/EC	dB (A)	104	
	7.6	Towing coupling, type DIN		PIN	



# DIMENSIONS

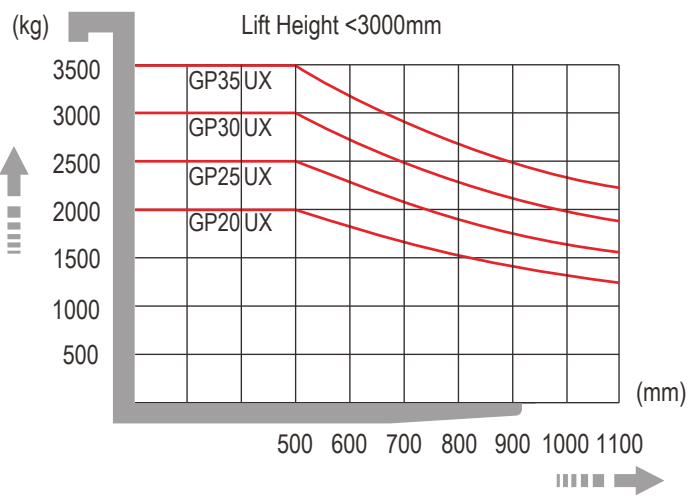
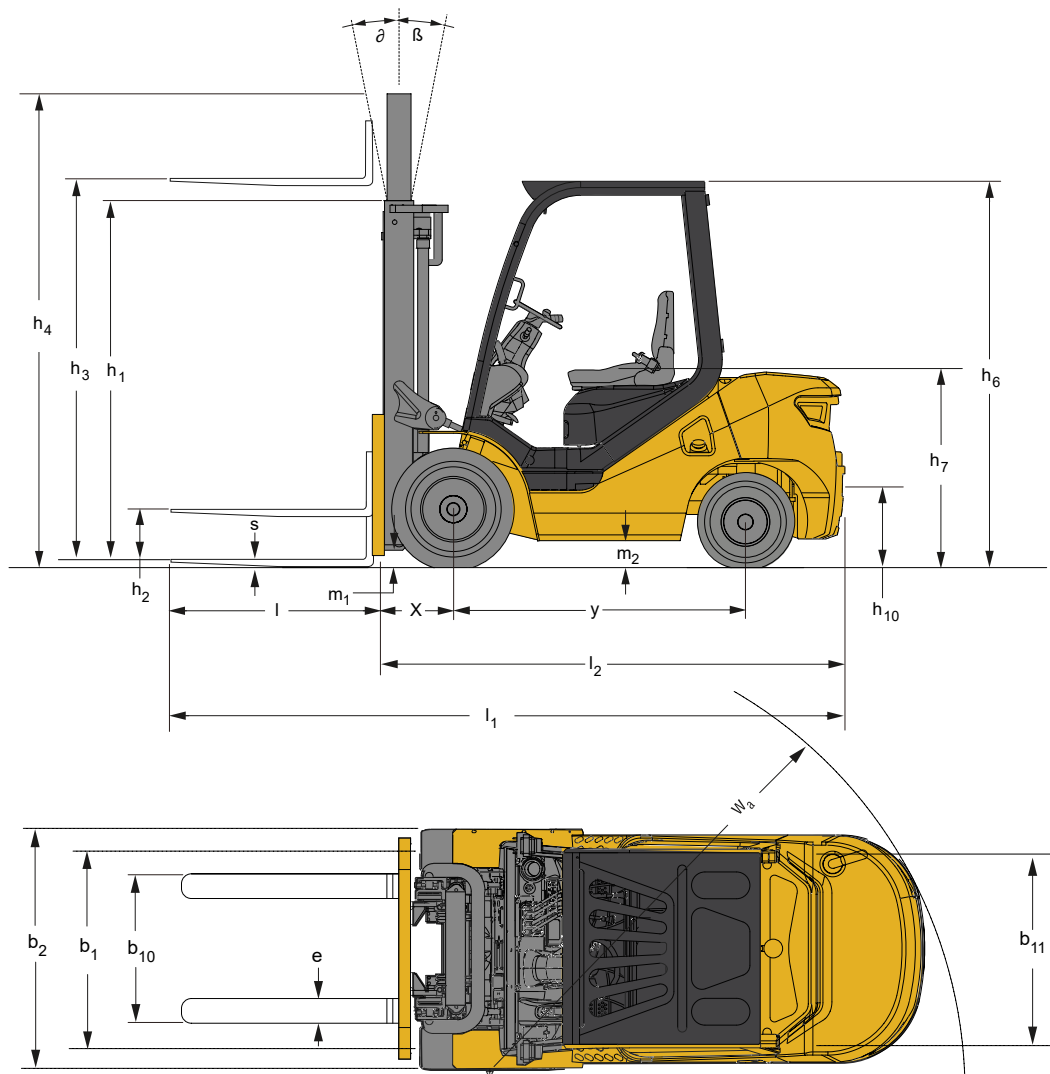

Yale® Dealer

 **PRESTAR MARKETING SDN BHD** 76838-X

Contact your nearest  
Yale® Dealership by visiting  
[www.prestarmarketing.com.my](http://www.prestarmarketing.com.my)



**Prestar Marketing Sdn Bhd**

**Operating Hours**

Monday - Friday 9:00 AM - 6:00 PM

Saturday - Sunday Closed

\*Closed on Public Holiday

 Lot 3811, Jalan 4D, Kampung Baru Subang, 40150 Shah Alam, Selangor, Malaysia.

 +603-7455 7070

 +603-7455 7066 / 7455 7099

 [inquiry@prestarmarketing.com](mailto:inquiry@prestarmarketing.com)

©Prestar Marketing Sdn Bhd 2023. All rights reserved. Specifications and details in this brochure are subject to change without prior notification.

**Penang**

 65-A, Jalan Perak, 10150 George Town,  
Pulau Pinang, Malaysia.

 +604-228 7100

 +604-229 5580

**Johor**

 4, Jalan Penaga 5, Kawasan Perindustrian Kota Puteri, 81750 Masai,  
Johor, Malaysia.

 +607-3880 323

 +607-3884 323

[www.prestarmarketing.com.my](http://www.prestarmarketing.com.my)



Manufactured in ISO 9001 and 14001 Registered Facilities

Trucks may be shown with optional equipment.

**Yale®**  
People. Products. Productivity.™