

STOCKYTM Pallet Truck Series

For Light-duty Applications

Stand On Power Pallet Truck
XPA20 /2000KG



FEATURES

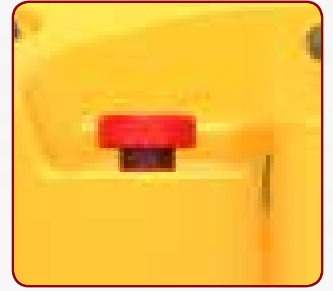

Safety Switch

Emergency power disconnect switch to quickly stop the truck.

Multi Function Handle

Frei tiller head/handle combines many functions in one: stepless driving speed control, horn, emergency reverse protection button, lifting and lowering buttons, etc.

Safety Side Guard

Soft PU side guard gives you more safety protection.

Shock absorption platform

The platform is with shock absorption, which improves the driving comfort of the truck, and relieves the working fatigue.



OVERVIEW

The Stocky Stand on Pallet Truck Series XPA20 provides the ideal solution to meet your less frequent usage needs, without compromising on performance.

Low Maintenance

The Stand on pallet truck features outstanding performance, comfortable operation, low use and maintenance cost. It is a good choice for material handling in supermarket, warehouse, workshop, etc.

Ergonomic Design

It is suitable for renting business by replacing lithium battery. And it is very popular and will be your idea choice for food, logistic, automobile warehousing, textile, printing, cold chain, clothing and other industries.



Battery Side Extraction

Battery can be pulled out from the side, making it very convenient to replace and maintain batteries.

**optional*



Double Front Balance Wheel

Easy entrance, smooth operation.

Benefits:

Exquisite design, consummate technique, excellent quality. New design, high safety, focus on perfect pursuit, man-machine perfect combination.

Industry Sectors:

- Wholesale Distribution
- Warehouse & 3PL
- Food Distribution & Processing
- Cold & Frozen Foods
- Building Material
- Home Centers
- General MFG
- Retail & E-Commerce (DC/fulfillment)
- Retail Store Operations
- Furniture & Furnishings
- Health & Pharma
- Auto Parts Distribution

○ FEATURES

ENGINEERED FOR DRIVERS



○ AC Driving

More accurate control, more stable operation.



○ Multi-Function Hour Meter

Hour meter can show battery charge level, operation time, error code, driving speed and steering angle (optional to shown on its screen).



○ Lifting Limit

Accurate control, reduce energy waste.



○ Big Power Hydraulic Pump

Low noise and vibration, making the operation smoother.



○ SPECIFICATIONS

1.1	Manufacturer	Measurement	STOCKY
1.2	Model designation		XPA20
1.3	Drive unit		Electric
1.4	Operation type		Standing
1.5	Load capacity	kg	2000
1.6	Load center	mm	600
1.7	Load distance, center of drive axle fork back	mm	191.5
1.7	Wheelbase	mm	1450
2.1	Truck weight (without battery)	kg	430
2.2	Axle loaded, front/rear	mm	1210/2006
3.1	Axle unloading, front/rear	mm	510/120
3.2	Tires		Polyurethane
3.3	Drive wheel size	mm	230*75
3.4	Loaded wheel size	mm	80*70
3.5	Balance wheel size	mm	100*40
3.6	Wheels number front/rear (x=driven wheels)	mm	1 x -2/4
4.1	Thread, front	mm	518
4.2	Thread, rear	mm	390
4.3	Height, fork lowered	h1 mm	1326
4.4	Lift height	h3 mm	205
4.5	Fork height, lowered	h5 mm	85
4.6	Height of tiller in drive position (max/min)	h6 mm	1246/985
4.7	Overall length	L1 mm	1908
4.8	Length to face of forks	L2 mm	758
4.9	Overall width	b1 mm	780
4.10	Fork dimensions s/e/c	mm	180/55/1150
4.11	Maximum fork width	b3 mm	570/680
4.12	Minimum ground clearance	M mm	30
4.13	Aisle width with pallets 800mm long x 1200mm wide	Ast mm	2312
4.14	Turning radius	mm	1716
4.15	Travel speed, loaded/unloaded	km/h	4.8/5.6
4.16	Lift speed, loaded/unloaded	mm/s	40/50
4.17	Lowering speed, loaded/unloaded	mm/s	50/40
4.18	Maximum gradeability loaded/unloaded	%	8/15
4.19	Service brake		Electromagnetic
4.20	Drive motor rating	kw	1.5
4.21	Lift motor rating	kw	2.2
5.1	Battery voltage/capacity - Lead Acid Battery	V/Ah	24/180
5.2	Battery weight	kg	170
5.3	Control unit type		Mosfet control
5.4	Noise level	dB(A)	<70



DIMENSIONS

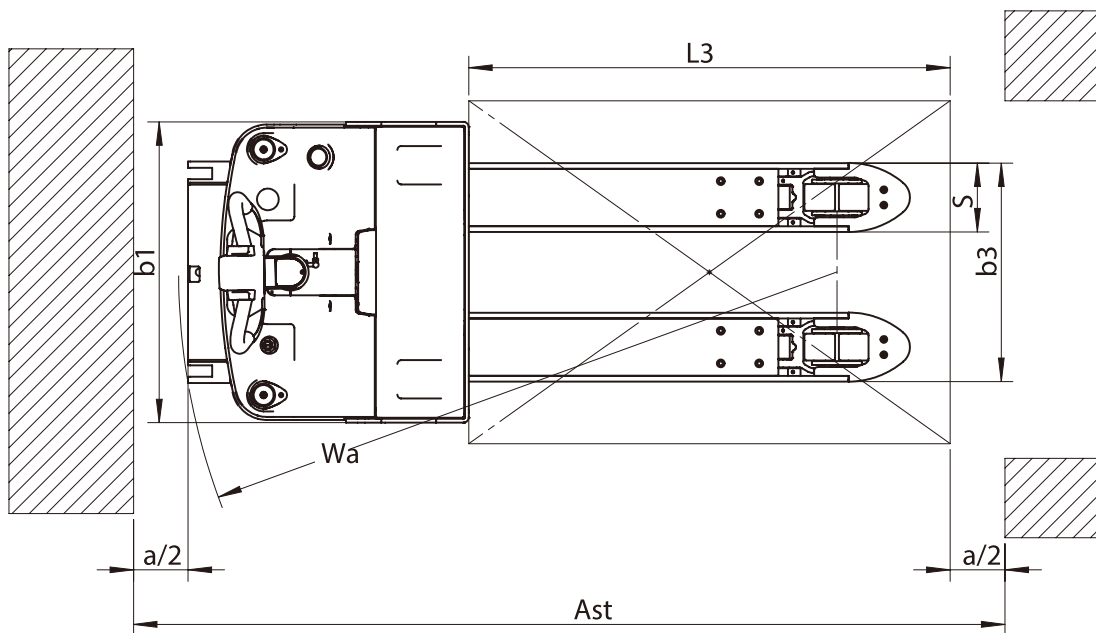
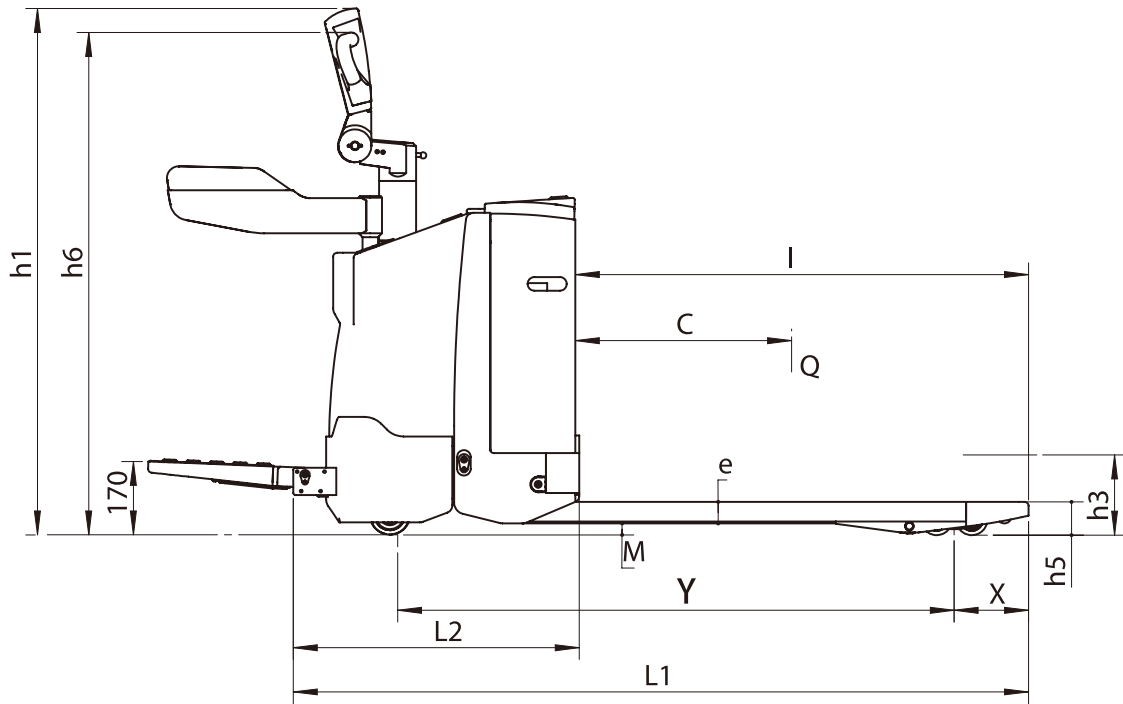

Contact your nearest
branch by visiting
www.prestarmarketing.com.my



Prestar Marketing Sdn Bhd

Operating Hours

Monday - Friday 9:00 AM - 6:00 PM

Saturday - Sunday Closed

*Closed on Public Holiday

📍 Lot 3811, Jalan 4D, Kampung Baru Subang, 40150 Shah Alam, Selangor, Malaysia.

☎ +603-7455 7070

📠 +603-7455 7066 / 7455 7099

✉ inquiry@prestar.marketing

©Prestar Marketing Sdn Bhd 2023. All rights reserved. Specifications and details in this brochure are subject to change without prior notification.

Penang

📍 65-A, Jalan Perak, 10150 George Town, Pulau Pinang, Malaysia.

☎ +604-228 7100

📠 +604-229 5580

Johor

📍 4, Jalan Penaga 5, Kawasan Perindustrian Kota Puteri, 81750 Masai, Johor, Malaysia.

☎ +607-3880 323

📠 +607-3884 323

www.prestarmarketing.com.my



Pallet Truck may be shown with optional equipment.